

MP918A and B Pneumatic Damper Actuators

Installation Instructions

Contents

Before Installation	2
Installation	3
General	3
Standard Mounting	3
External Mounting	3
Internal Mounting	5
Normally Closed Mounting	5
Normally Open Mounting	5
Nonstandard Mounting	6
General	6
External Mounting	6
Offset Crankarm Mounting	6
Actuator Shaft Extension Mounting	7
Top Mounting	9
Alternate Top Mounting	9
Internal Mounting	10
Jackshaft Installation	10
Jackshaft and Kit Mounting	10
Internal Damper Frame Mounting	15
Internal Duct Floor Mounting	16
External Mounting	16
Actuator Converting	17
Converting Internally Mounted Normally Open Actuator to External Mounting	17
Converting Internally Mounted Normally Closed Actuator to External Mounting	17
Piping	17
MP918A Actuator Piping	17
MP918B Actuator Piping	17
Slave Actuator Piping	17
Positioner Adjustment (MP918A Only)	18
Start Point Adjustment	18
Calibration Adjustment	18

BEFORE INSTALLATION

This installation literature covers MP918A and B Pneumatic Damper Actuators which can be mounted in any position and installed either externally or internally. The MP918A includes a positive positioner. To install MP918A and B UL Listed Pneumatic Damper Actuators, refer to 95-6075. Internally mounted, normally open applications for dampers with 12-inch B dimension are not covered in this literature. Consult the factory.

Tools needed:

The following tools are required to install MP918A and B Actuators:

- 7/16-inch box end wrench
- 1/8-inch Allen wrench
- Squeeze bulb

NOTE: Use squeeze bulb to stroke (operate) unpiped actuators during adjustment.

Optional Accessories:

Accessories from the following list are needed for some of the installation procedures in this literature. These are obtained separately from the actuator or damper. Review these instructions to see that the required accessories are available for the installation.

- Adapter for Internal Side Mount: 14004236-001
- Alternate Top Mount Assembly: 14004324-001
- Balljoint and Adapter Assembly: 14004242-001 (for jackshaft installation)
- Conversion Kit to convert MP918B, 8 to 13 psi (55 to 90 kPa) spring range, to MP918A: 14004264-002. Contains 10 psi (69 kPa) span feedback spring.

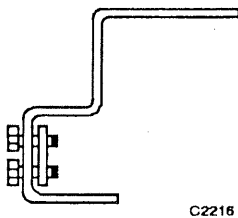

Fig. 1. Offset Crankarm.

- Crankarm Assembly: 14004107-001 (conversion of internal normally closed to external)
- End Kit: 15753693-001 (for jackshaft installation)
- External Drive Axle Hardware Assembly: 14004313-003
- Feedback Spring Kit for 3 psi (21 kPa) span (MP918A): 14004509-001 (10 springs per kit)
- Hitch Pin Assembly: 14004241-002 (contains six clevis pins)
- Modular Kit: 15753692-001 (for jackshaft installation)
- Mounting Screw Assembly: 14004237-001 (conversion of internal mounting models to external)
- Offset Crankarm (Fig. 1): 14004667-001 (for 1/2-inch damper drive shaft, 1.9-inch offset)
- Operator Kit: 15753694-001 (for jackshaft installation)
- Positioner Feedback Spring Kit: 14004210-001. Contains one 3, 5, and 10 psi (21, 35, and 69 kPa) span spring.
- Push Rod Assembly: 14004106-001 (conversion of internal normally closed to external)
- Right-Hand Drive Ear Hardware Assembly (Fig. 2): 14004313-001 (for internal normally closed mounting)
- Right-Hand Drive Ear Hardware Assembly (Fig. 3): 14004313-002 (for internal normally open mounting)
- 5/16-Inch Diameter Pushrod: 27520 (order to length required)
- 3/8-16 Threaded Rod: CCT2718 (for shaft extension)
- 3/8-16 Rod Coupling: CCT2725 (for shaft extension)
- 3/8-16 Hex Nuts: CCT2361 (for shaft extension)

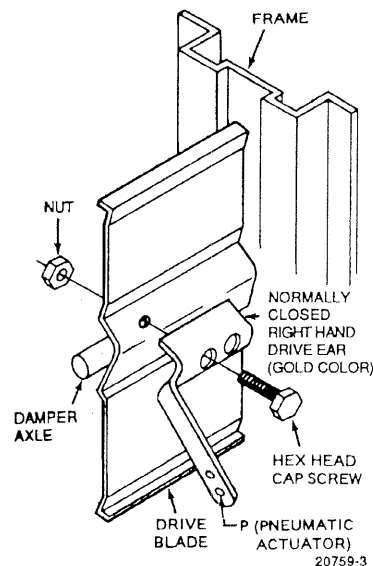

Fig. 2. Normally Closed Drive Ear Mounting.

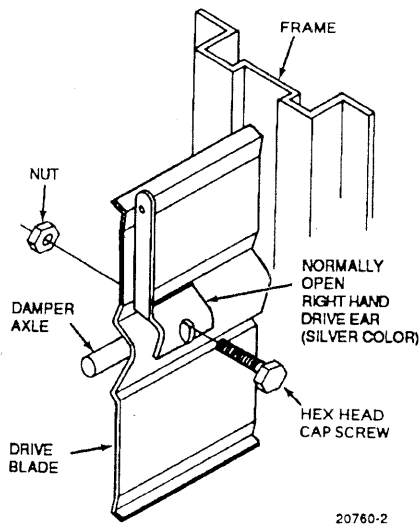

Fig. 3. Normally Open Drive Ear Mounting.

INSTALLATION

GENERAL

The MP918 Damper Actuator can be installed externally or internally. There are two mounting approaches: standard and nonstandard. Use nonstandard mounting when standard mounting is not practical (e.g., for extra clearance or non-Honeywell dampers). It may require ordering additional parts.

STANDARD MOUNTING

EXTERNAL MOUNTING

1. See Figure 4 for mounting dimensions.
2. Check faceplate position and adjust if necessary (Fig. 5).
3. Determine the damper drive axle direction of rotation to the normal position (normally open or normally closed).
4. Rotate damper drive axle to normal position (position with 0 psi to actuator).

5. Install actuator with appropriate shaft hole (Fig. 6) on mounting bracket over damper shaft. Arrow on bracket surrounding hole should match rotation determined in Step 3.
6. Position bracket.
7. Secure mounting bracket. Use four of the 10 holes available in bracket and drill screws provided.
8. To provide close-off force, use a squeeze bulb and stroke the actuator:
 - a. For normally open dampers, fully extend actuator shaft, then retract 1/8-inch (3 mm).
 - b. For normally closed dampers, extend actuator shaft 1/8-inch (3 mm).
9. Secure crankarm to damper drive axle.

CAUTION

See Figure 7 for proper crankarm bolt tightening.

10. Go to PIPING section.

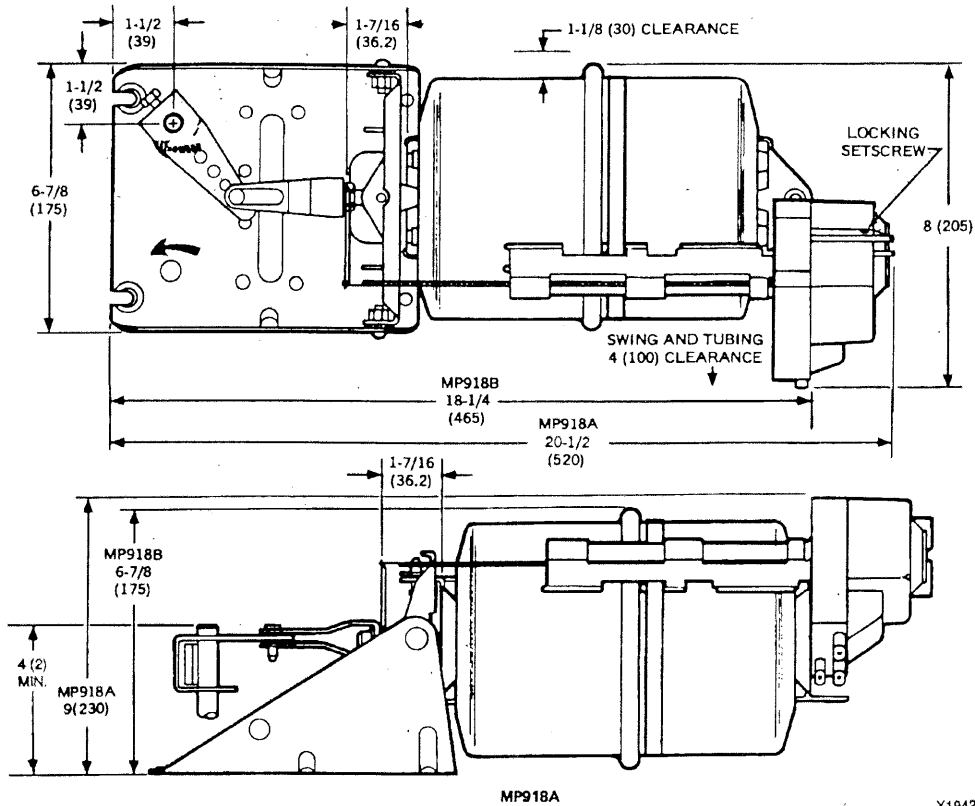

Fig. 4. External Mounting Dimensions in Inches (Millimeters).

X1942-4

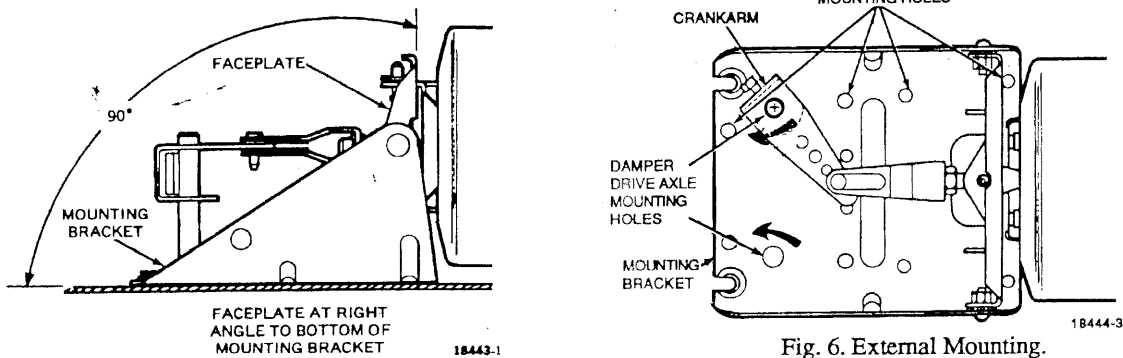
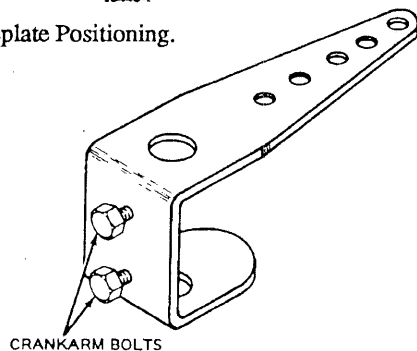

Fig. 5. External Mounting Faceplate Positioning.

Fig. 6. External Mounting.



- CRANKARM BOLTS
1. BOLTS ARE TORQUED TO MORE THAN 90 LB-IN. BUT LESS THAN 200 LB-IN.
 2. TIGHTEN BOTH BOLTS (WITH 7/16 BOX END WRENCH IF AVAILABLE).
 3. TIGHTEN EACH BOLT AGAIN TO THE REQUIRED TORQUE.

18445-2

Fig. 7. Crankarm Bolt Tightening.

INTERNAL MOUNTING

NORMALLY CLOSED MOUNTING

1. See Figure 8 for internal mounting normally closed dimensions.
2. Check faceplate position and adjust if necessary (Fig. 9). The faceplate must be parallel to the back of the mounting bracket.
3. Use 1/8-inch Allen wrench to loosen mounting setscrews on damper mounting clamp (Fig. 9) one turn. Remove and discard shipping stop.
4. Loosen faceplate nut between mounting bracket and truss link. Remove clevis pin from actuator pushrod.

5. Find factory-installed drive ear on damper blade (mounted per Damper Ordering Instructions). Mount actuator(s) only in this (these) position(s).
6. Set actuator in place by hooking damper mounting clamp over bottom edge of damper.
7. Set damper to its normal (closed) position.
8. Reinsert clevis pin through drive ear and actuator pushrod.
9. Connect truss link to damper with mounting screw and tighten faceplate nuts.
10. Tighten on damper mounting clamp.
11. Go to PIPING section.

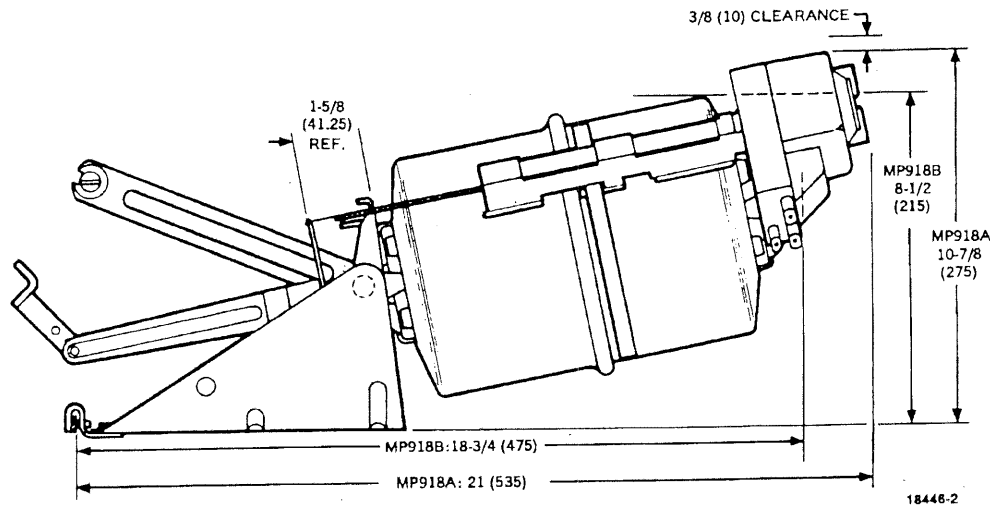

Fig. 8. Internal Mounting Normally Closed Dimensions in Inches (Millimeters).

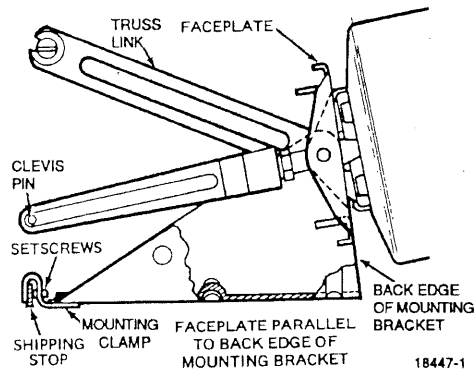

Fig. 9. Internal Mounting Normally Closed Faceplate Positioning.

NORMALLY OPEN MOUNTING

1. See Figure 10 for internal mounting normally open dimensions.
2. Check faceplate position and adjust if necessary (Fig. 9). The faceplate must be parallel to the back of the mounting bracket.

3. Use 1/8-inch Allen wrench to loosen mounting setscrews on damper mounting clamp one turn (Fig. 11). Remove and discard shipping stop.
4. Determine height of damper drive blade. Dampers with 10 (254), 12 (309), 18 (457), 26 (660), 34 (864), and 48-inch (1219 mm) height have 8-inch (203 mm) drive blades. All others have 6-inch (152 mm) drive blades.
5. For installation with 6-inch (152 mm) drive blades skip this step and go on to Step 6. For 8-inch (203 mm) drive blades, remove Clevis Pin A from damper pushrod clevis pin hole marked 6 and reinstall in clevis 8 pin hole marked 8 (Fig. 11). (Mate with crankarm hole marked 90.)
6. Loosen faceplate nut between mounting bracket and truss link (Fig. 11). Remove Clevis Pin C from damper pushrod.
7. Find factory-installed drive ear on damper blade (mounted per Damper Ordering Instructions). Mount actuator(s) only in this (these) position(s).
8. Set actuator in place by hooking damper mounting clamp over bottom edge of damper.

9. Set damper to its normal (open) position.
10. Connect damper pushrod to damper drive ear with Clevis Pin C.
11. Connect truss link to damper with mounting screw and tighten faceplate nuts.

12. Tighten setscrews on damper mounting clamp.
13. Go to PIPING section.

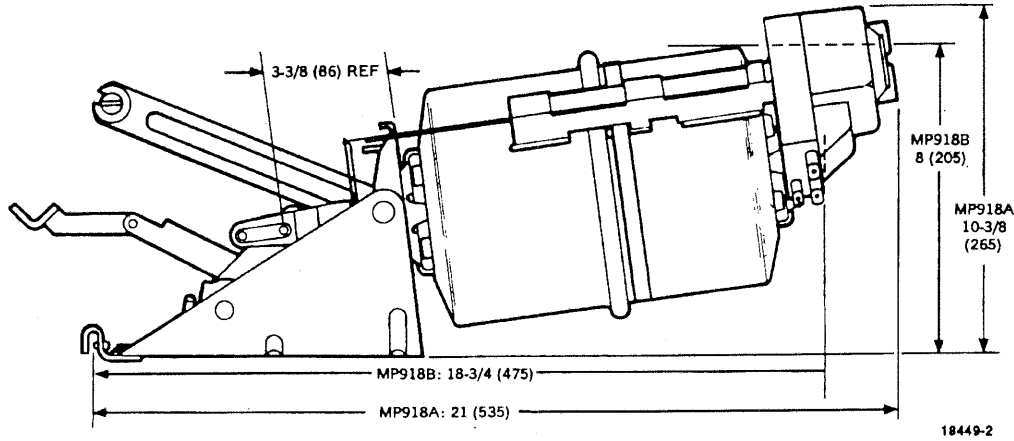

Fig. 10. Internal Mounting Normally Open Dimensions in Inches (Millimeters).

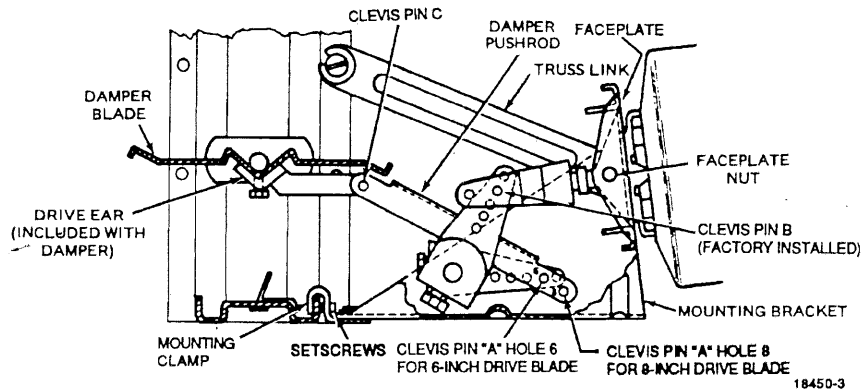

Fig. 11. Internal Mounting Normally Open Installation.

NONSTANDARD MOUNTING

GENERAL

This section describes nonstandard installations. It includes:

- A procedure to use an offset crankarm to allow installation to short drive axles without using couplings and extensions. A 1.9-inch (48 mm) offset is provided.
- A procedure to add an actuator shaft extension when the actuator cannot be mounted in the proximity of the damper shaft.
- Two methods for mounting the damper actuator on top of the duct to drive the damper crankarm. (The first method, TOP MOUNTING, uses an actuator shaft extension.)

Extra installation time may be needed. Additional necessary parts are listed.

EXTERNAL MOUNTING

OFFSET CRANKARM MOUNTING

1. Obtain one 14004667-001 offset crankarm (Fig. 1).
2. Remove the standard crankarm (Fig. 12A) from the actuator and install the offset crankarm (Fig. 12B).
3. Mount the actuator and secure the offset crankarm to the drive axle as covered in EXTERNAL MOUNTING.

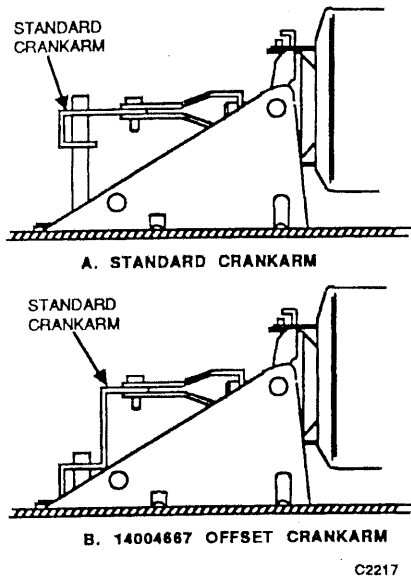

Fig. 12. Installing Offset Crankarm.

ACTUATOR SHAFT EXTENSION MOUNTING

- Obtain the following additional parts:
 - One 3/8-16 Threaded Rod: CCT2718 (for shaft extension)
 - One 3/8-16 Rod Coupling: CCT2725 (for shaft extension)
 - Two 3/8-16 Hex Nuts: CCT2361 (for shaft extension)
- Remove clevis pin, washer, and clip (Fig. 13), disconnect actuator pushrod from crankarm, and unscrew actuator pushrod from actuator shaft.

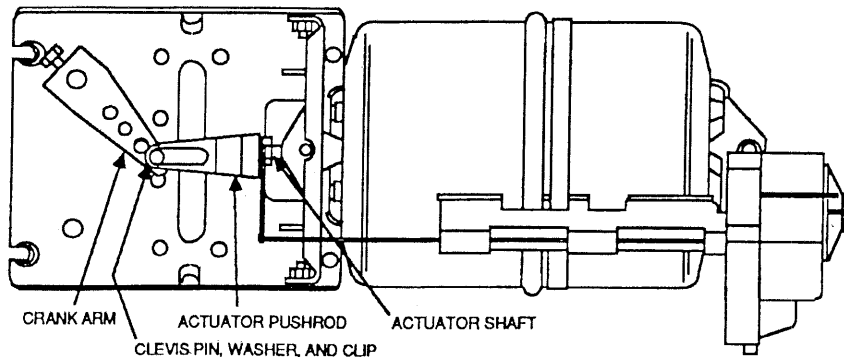

Fig. 13. Removing Pushrod.

- Remove two clevis pins, washers, and clips, and disconnect actuator from faceplate (Fig. 14).
NOTE: For MP918A, unhook feedback spring.

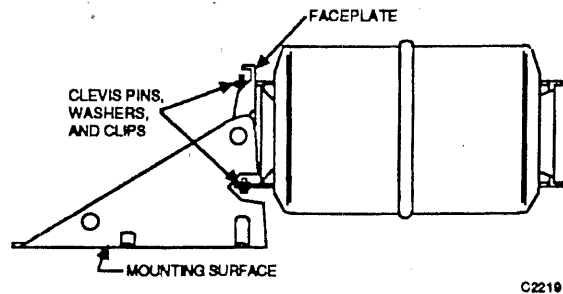

Fig. 14. Removing Faceplate.

- Install mounting bracket using four mounting screws provided (Fig. 15).

NOTES:

- Location should allow use of a straight shaft extension.
- Maximum recommended distance between damper axle and mounting bracket faceplate is 41 inches (1041 mm).
- Use the minimum distance practical for the installation.

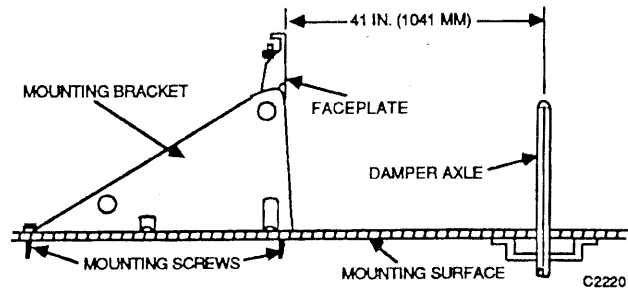

Fig. 15. Mounting Bracket Installation.

5. Install actuator to faceplate using the two clevis pins, washers, and clips from Step 3 as shown in Figure 16.

NOTE: For MP918A, rehook feedback spring.

6. For offset shaft installation, bend threaded rod CCT2718 as required. Use 45-degree bends with a maximum of 3-inch (76 mm) offset.
7. Cut threaded rod 5 inches (127 mm) shorter than faceplate to damper axle distance as determined in Step 4.
8. Assemble threaded rod, pushrod, coupling, and nuts to form actuator shaft extension (Fig. 17).

USE THESE HOLES IF FACEPLATE TO DAMPER IS LESS THAN 15 INCHES. (PINS IN AXIS PARALLEL TO DAMPER AXLE)

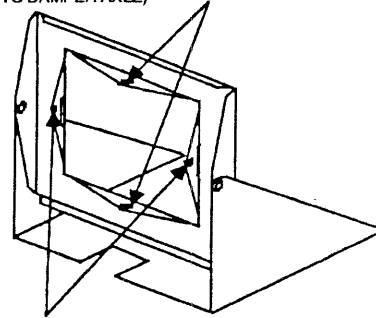

USE THESE HOLES IF FACEPLATE TO DAMPER IS EQUAL TO OR GREATER THAN 15 INCHES. (PINS IN AXIS PERPENDICULAR TO DAMPER AXLE)

C2221

Fig. 16 Faceplate Installation.

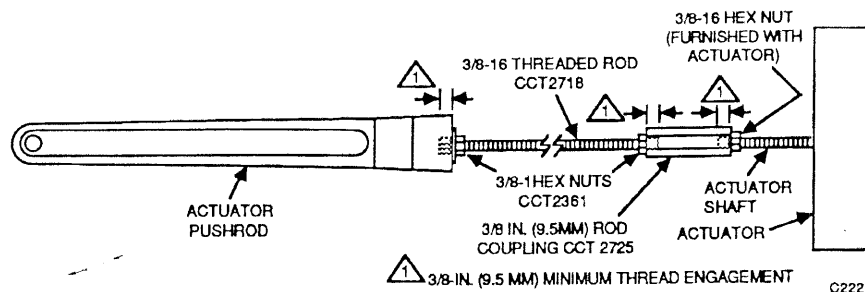

C2222

Fig. 17. Assembling Actuator Shaft Extension.

9. Adjust the threaded rod length for a 1/8-inch (3.2 mm) clinch at damper closure as follows:
 - a. Rotate damper axle to closed damper position.
 - b. If linkage is normally open, pressurize actuator to fully extended position.
 - c. Adjust actuator pushrod to obtain a 1/8-inch (3.2 mm) misalignment in pushrod to crankarm clevis pin hole (Fig. 18).
 - d. If linkage is normally open, remove pressure to actuator. If linkage is normally closed, pressurize to stroke actuator at least 1/8-inch (3.2 mm).
 - e. Align pushrod and crankarm clevis pin holes and insert clevis pin. Fasten clevis pin using washer and clip from Step 2.
 - f. Tighten hex nuts on actuator shaft and threaded rod (Fig. 17) to lock rod in place.
10. Go to PIPING section.

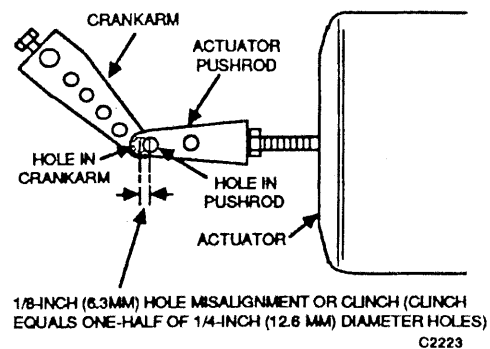

C2223

Fig. 18. Threaded Rod Installation.

TOP MOUNTING

- Obtain the following additional parts:
 - One 3/8-16 Threaded Rod: CCT2718 (for shaft extension)
 - One 3/8-16 Rod Coupling: CCT2725 (for shaft extension)
 - Two 3/8-16 Hex Nuts: CCT2361 (for shaft extension)
- Move damper to normal position with 0 psi applied to actuator.
- Loosen locknut and remove factory-installed pushrod from actuator shaft (Fig. 19).
- Loosen faceplate nuts, rotate faceplate parallel to bottom of mounting bracket, and retighten the faceplate nuts.
- Screw 3/8-16 rod coupling onto actuator shaft.
- Tighten locknut on actuator shaft against coupling.
- Attach pushrod to crankarm.
- Secure crankarm to damper drive axle.

CAUTION

See Figure 7 for proper crankarm bolt tightening.

- Use mounting bracket as a template and mark four mounting screw locations.
- Secure mounting bracket with four 14 x 1-inch slotted hexhead sheet metal screws provided.
- Cut threaded rod to length.
- Screw locknuts on both ends of threaded rod.
- Install one end of threaded rod on rod coupling of actuator shaft and the other end on pushrod connected to damper crankarm.
- If preload is desired, use a squeeze bulb and stroke actuator approximately 1/8-inch (3 mm).
- Tighten locknuts on threaded rod.
- Go to PIPING section.

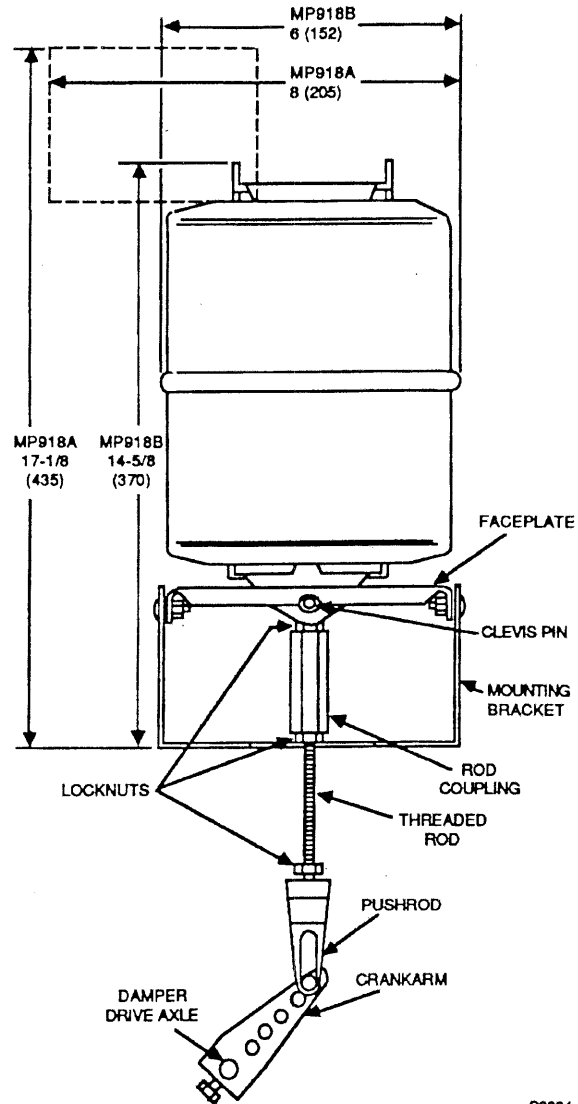

C2224

Fig. 19. Nonstandard Top Mount Installation.
Dimensions in Inches (Millimeters).

ALTERNATE TOP MOUNTING

- Obtain the following additional parts:
 - Alternate Top Mount Assembly: 14004324-001. Consists of:
 - One Crankarm Shaft: 313661
 - Two Bearings: 1400028-001
 - Two Crankarm Assemblies: 14004107-001
 - Two Balljoints: 315321
 - 5/16-Inch Diameter Pushrod: 27520 (order to length required)
- Move damper to normal position with 0 psi applied to actuator.
- Remove two clevis pins and separate the actuator from the mounting bracket.
- Rotate actuator 90 degrees counterclockwise and reinstall clevis pins. Loosen faceplate nuts and

align faceplate so that mounting bracket and faceplate are parallel as shown in Figure 20. Tighten faceplate nuts.

- Loosen locknut and screw or unscrew actuator pushrod to dimension shown in Figure 21. Tighten locknut.
- Fit white plastic bearings into place (Fig. 21) with flange on outside of mounting bracket.
- Slide crankarm shaft through crankarm connected to actuator pushrod (Fig. 21).

NOTE: Crankarm shaft can be extended to either side (Fig. 21).

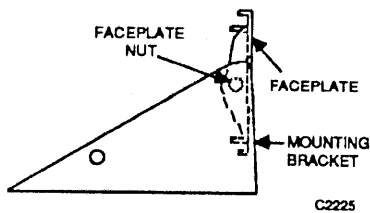

Fig. 20. Alternate Top Mount Faceplate Positioning.

8. Tighten bolts on crankarm connected to actuator pushrod (Fig. 21).

CAUTION

See Figure 7 for proper crankarm bolt tightening.

9. Use mounting bracket as a template and mark four mounting screw locations.
11. Secure mounting bracket with four 14 x 1-inch slotted hexhead sheet metal screws provided.
11. Install balljoints on the crankarms.
12. Connect one crankarm from the bag assembly to the extended end of the crankarm shaft (Fig. 21).

CAUTION

See Figure 7 for proper crankarm bolt tightening.

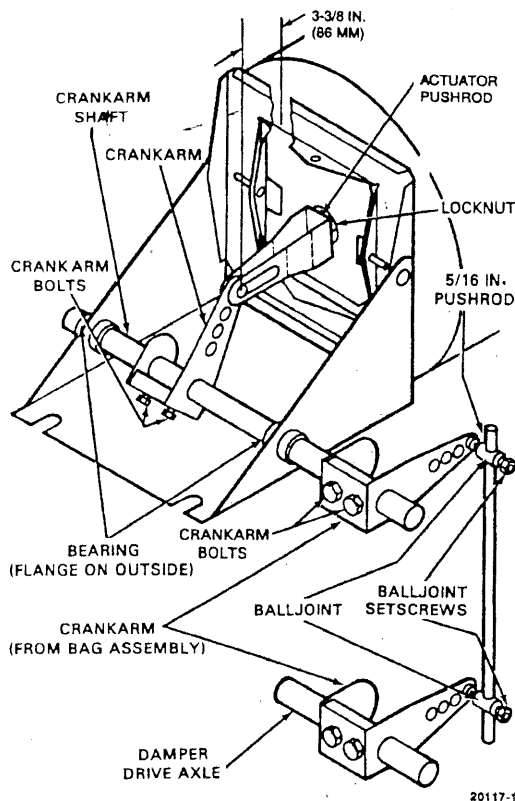

Fig. 21. Alternate Top Mount Crankarm Installation.

13. Connect the remaining crankarm to the damper drive axle (Fig. 21).

CAUTION

See Figure 7 for proper crankarm bolt tightening.

14. Cut 5/16-inch pushrod to length.
15. Slide pushrod onto balljoints.
16. If preload is desired, use a squeeze bulb and stroke actuator approximately 1/4-inch (6 mm).
17. Tighten balljoint setscrews.
18. Go to PIPING section.

INTERNAL MOUNTING

In non-Honeywell damper installations use Balljoint and Adapter Assembly 14004242-001 and 5/16-Inch Diameter Pushrod 27520 (order to length) to adapt to damper.

JACKSHAFT INSTALLATION

Installation procedures follow for mounting the Jackshaft and Kits. Three ways of mounting an actuator using the jackshaft kits are also included: Internal Damper Frame Mounting, Internal Duct Floor Mounting, and External Mounting.

JACKSHAFT AND KIT MOUNTING

Damper jackshaft installation uses combinations of three separate kits for different installations. These are illustrated in Figures 22 through 24. Figures 25 and 26 illustrate typical installations for normally closed or normally open dampers. Review these figures carefully before installing.

The jackshaft itself must be provided locally and meet the following specifications: It must be 3/4-inch (nominal) galvanized steel pipe, schedule 40 (standard) thickness. It can be of one continuous length, or it can be made up of shorter lengths joined by threaded pipe ends using a standard threaded coupling. The coupling and pipe ends must be drilled through and locked together with bolts.

1. Obtain the following parts:

- End Kit: 15753693-001 (Fig. 22 and Table 1), one for each installation
- Modular Kit: 15753692-001 (Fig. 23 and Table 2), one for each adjacent, vertical damper bank
- Operator Kit: 15753694-001 (Fig. 24 and Table 3), one for each actuator

2. Attach support brackets from end kit and modular kit(s) to sides of damper frame.

NOTE: Mounting holes in brackets will match holes in the frame at only one location. See Figures 25 and 26.

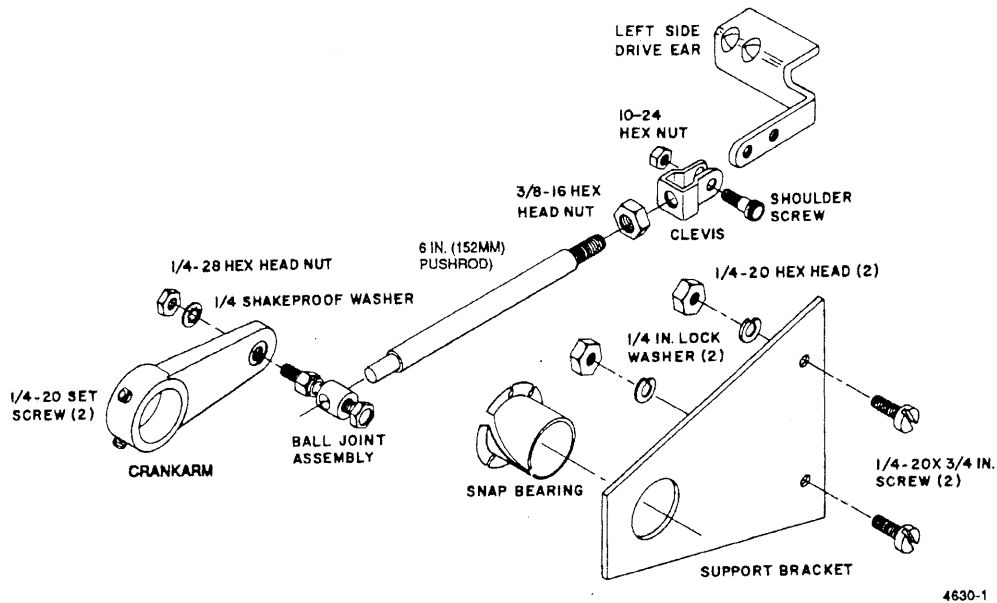

4630-1

Fig. 22. End Kit Assembly.

Table 1. End Kit Parts.

Qty.	Part No.	Description
2	6220	Lockwasher 1/4 in.
2	7289-21	Nut 1/4-20 hex head
2	80895AB	Screw 1/4-20 x 3/4
1	14000644-004	Left side drive ear
1	14000672-001	Shoulderscrew
1	14000767-001	Nut 10-24 hex head
1	315439	Clevis
1	304814-767	Nut 3/8-16 hex head
1	14000645-004	6 in. push rod
1	315321	Balljoint assembly
2	14000168-366	Set screw 1/4-20
1	15753688-001	Crankarm
1	15753675-001	Snap bearing
1	15753674-001	Support bracket

T588

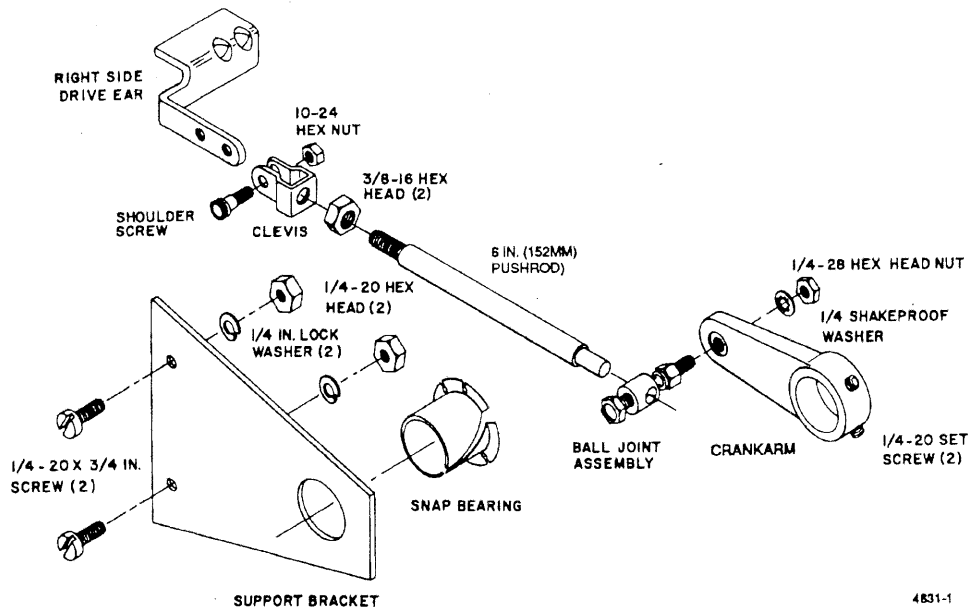
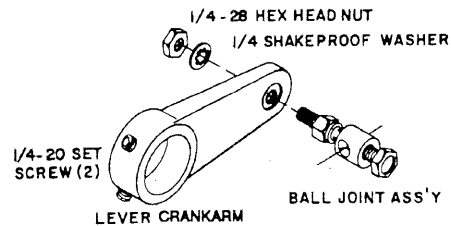

Fig. 23. Modular Kit Assembly.

Table 2. Modular Kit Parts.

Qty.	Part No.	Description
2	6220	Lockwasher 1/4 in.
2	7289-21	Nut 1/4-20 hex head
2	80895AB	Screw 1/4-20 x 3/4
1	14000644-002	Right side drive ear
1	14000672-001	Shoulder screw
1	14000767-001	Nut 10-24 hex head
1	315439	Clevis
1	304814-767	Nut 3/8-16 hex head
1	14000645-004	6 in. push rod
1	315321	Balljoint assembly
2	14000168-366	Set screw 1/4-20
1	15753688-001	Crankarm
1	15753675-001	Snap bearing
1	15753674-001	Support bracket

T589



4632

Fig. 24. Operator Kit Assembly.

Table 3. Operator Kit Parts.

Qty.	Part No.	Description
1	315321	Balljoint assembly
2	14000168-366	Set screw 1/4-20
1	15753688-001	Crankarm

T590

3. Insert snap bearings from kits into brackets.
4. Cut jackshaft to length. Smooth off rough edges.
5. Install jackshaft and crankarms.
NOTE: Be sure to install crankarms from operator kits.
6. Secure drive ears to damper blades.
7. Attach balljoint assembly to crankarms.
8. Assemble push rod and clevis. Tighten nut against clevis.
9. Insert pushrod into balljoint assembly.
10. Secure clevis to drive ear using shoulder screw and nut.

11. Align and tighten crankarms using Allen wrench.
12. Tighten balljoint setscrews to hold push rod.
NOTE: If there is insufficient clearance to insert shaft through bearings after brackets are mounted, the order of Steps 2 through 5 can be altered.
13. Go to one of the following actuator mounting sections: INTERNAL DAMPER FRAME MOUNTING, INTERNAL DUCT FLOOR MOUNTING, or EXTERNAL MOUNTING.

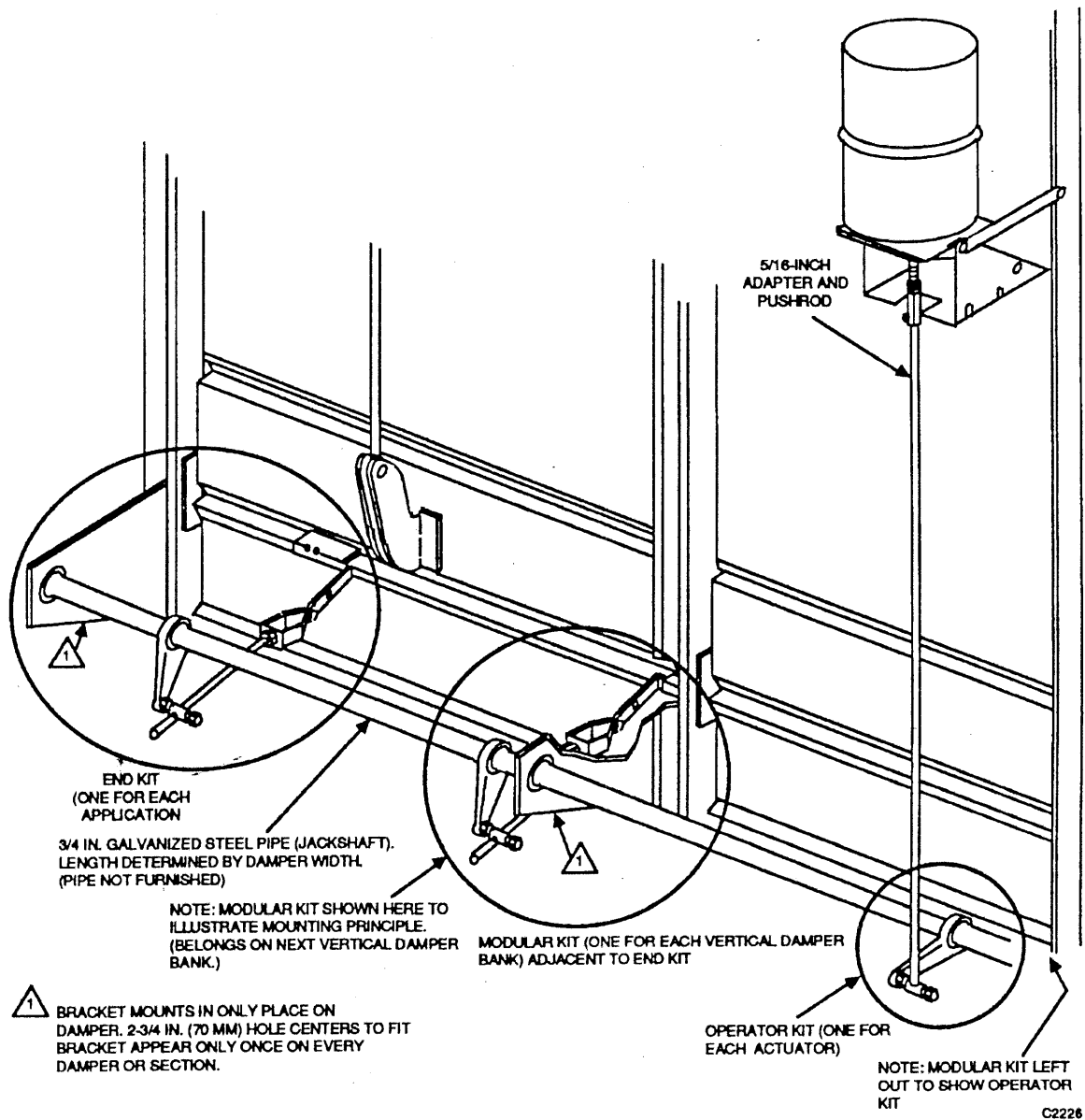

Fig. 25. Normally Closed Damper Jackshaft Installation.

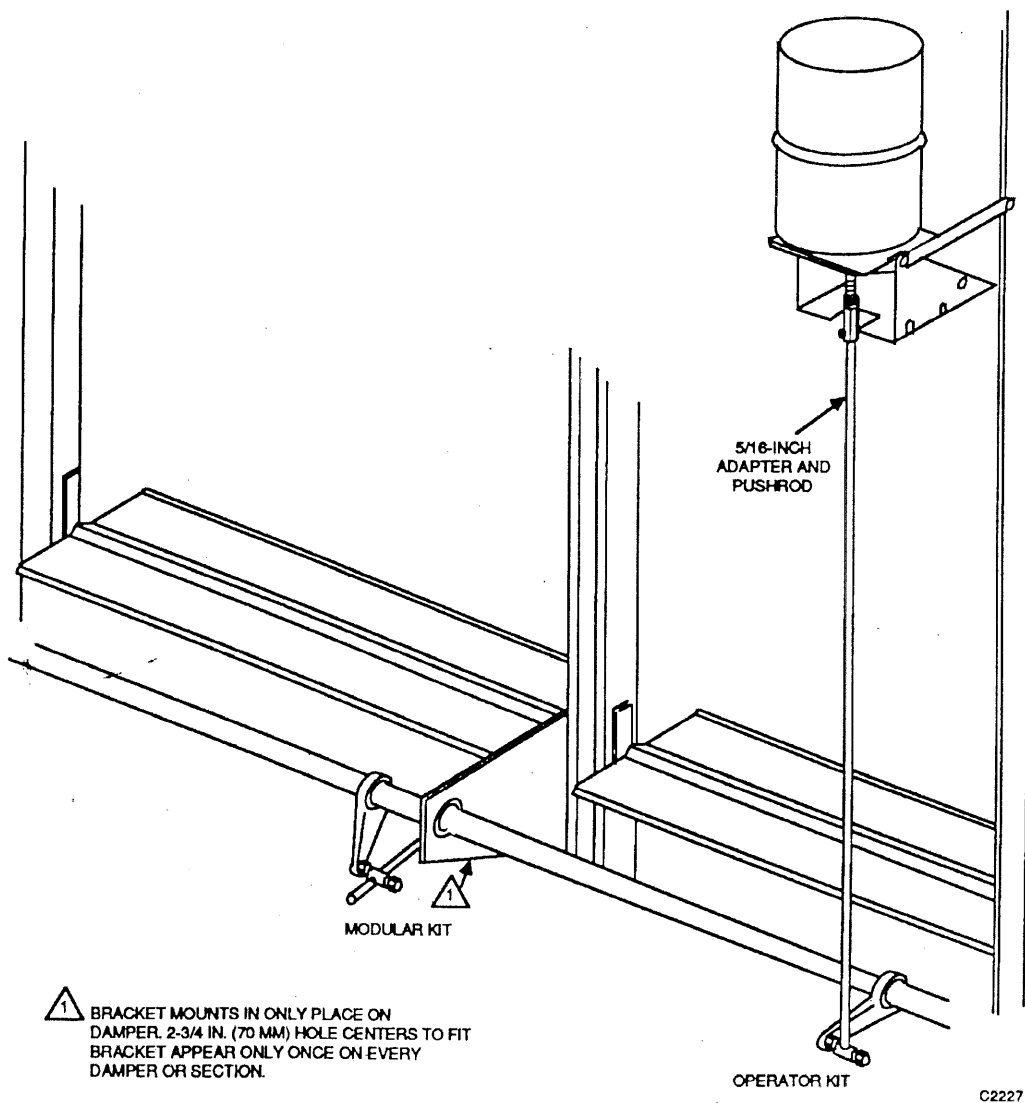

Fig. 26. Normally Open Damper Jackshaft Installation.

INTERNAL DAMPER FRAME MOUNTING

Use internal-mount, normally closed damper actuator (Fig. 27).

1. Obtain the following additional parts:
 - Balljoint and Adapter Assembly: 14004242-001
 - 5/16-Inch Diameter Pushrod: 27520 (order to length required)
2. Loosen locknut and remove factory-installed pushrod.
3. Use 1/8-inch Allen wrench to loosen mounting setscrews on damper mounting clamp one turn. Remove and discard shipping stop.
4. Remove mounting screw from damper end of truss link. Loosen faceplate nuts between mounting bracket and truss link.
5. Set actuator in place by hooking actuator mounting clamp over bottom edge of an upper damper frame.
6. Connect truss link to damper frame and tighten mounting screw.
7. Tighten mounting setscrews.
8. Move damper to normal position with 0 psi applied to actuator.
9. Rotate the actuator to vertical position and retighten the faceplate nuts.
10. Screw adapter onto the actuator shaft and tighten the locknut against the adapter.
11. Cut 5/16-inch pushrod to length.
12. Slide pushrod into balljoint and slip into adapter.
13. Tighten adapter setscrew.
14. If preload is desired, use a squeeze bulb and stroke actuator approximately 1/4-inch (6 mm).
15. Tighten balljoint setscrew.
16. Go to PIPING section.

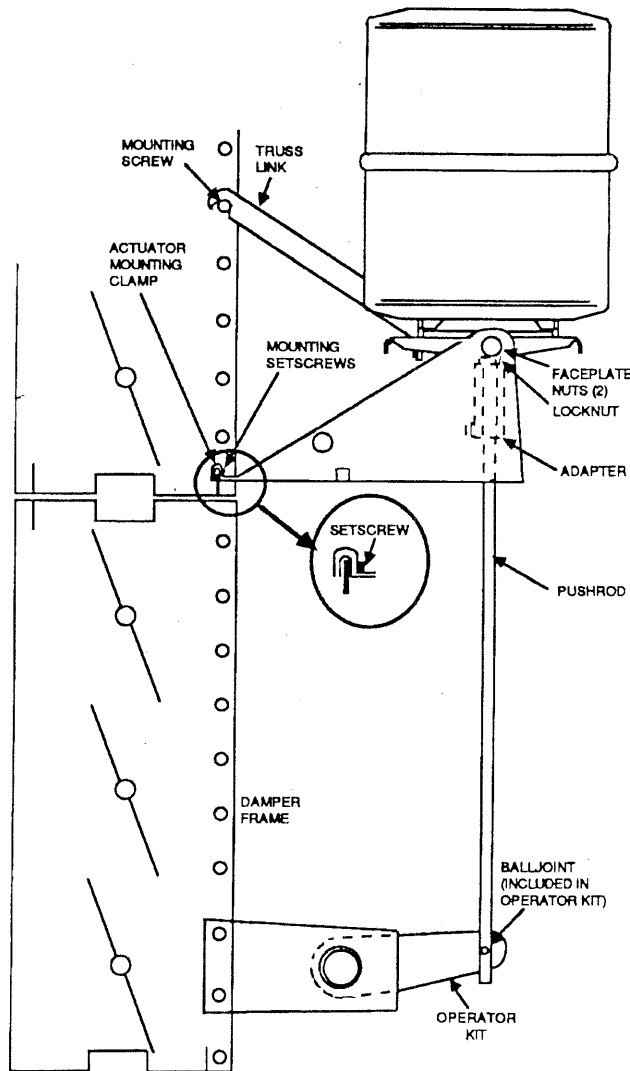

Fig. 27. Internal Mounting on Damper Frame.

INTERNAL DUCT FLOOR MOUNTING

1. Obtain the following additional parts:

- Balljoint and Adapter Assembly: 14004242-001
- 5/16-Inch Diameter Pushrod: 27520 (order to length required)

2. Mount actuator inside duct (Fig. 28). Use balljoint included in operator kit.

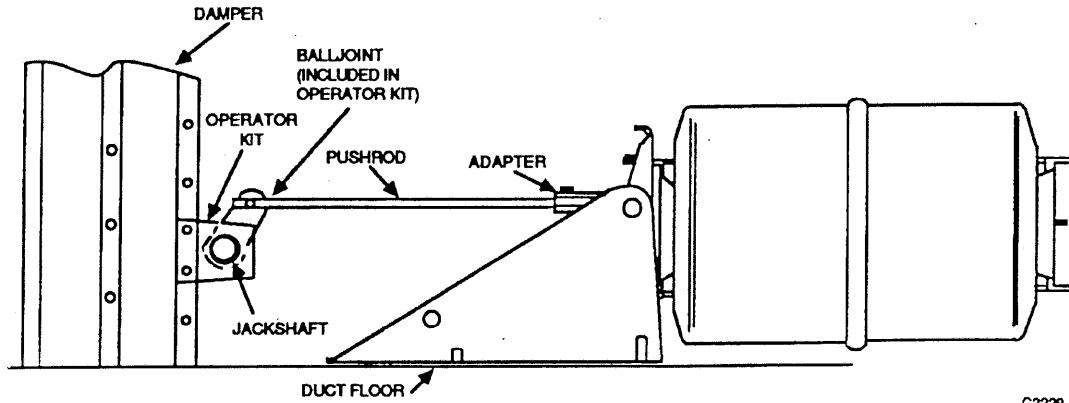

C2229

Fig. 28. Internal Mounting on Duct Floor Using Operator Kit.

EXTERNAL MOUNTING

1. Obtain the following additional parts:

- Balljoint and Adapter Assembly: 14004242-001
- 5/16-Inch Diameter Pushrod: 27520 (order to length required)

2. Extend jackshaft to the outside of the duct and mount actuator externally (Fig. 29). Use balljoint included in operator kit.

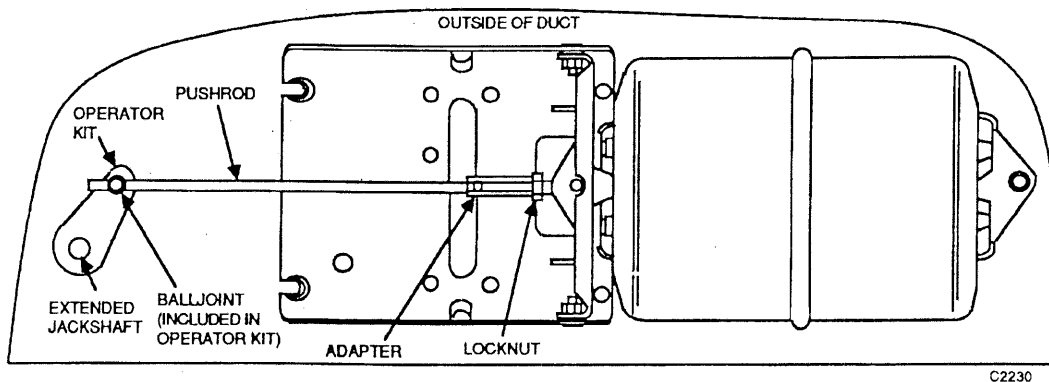

C2230

Fig. 29. External Mounting Using Operator Kit.

ACTUATOR CONVERTING

If damper actuator is ordered for internal mounting but internal mounting is impractical, obtain the proper actuator or convert using the following procedures.

CONVERTING INTERNALLY MOUNTED NORMALLY OPEN ACTUATOR TO EXTERNAL MOUNTING

1. Obtain the following additional parts:
 - Mounting Screw Assembly: 14004237-001
 - External Drive Axle Hardware Assembly: 14004313-003
2. Remove all four clevis pins (Fig. 30).
3. Loosen all four crankarm bolts.
4. Slide out crankarm shaft and discard shaft, one crankarm, and damper pushrod.
5. Loosen two damper mounting clamp screws and remove clamp if necessary.
6. Loosen faceplate nut, remove truss link, and retighten nut.
7. Loosen locknut and adjust pushrod to dimensions shown on Figure 31. Tighten locknut.
8. Reinstall actuator noting change in clevis pin location (Fig. 31).
9. Install one of the crankarms on the pushrod with a clevis pin (Fig. 31).
10. Install actuator using standard external mounting instructions.

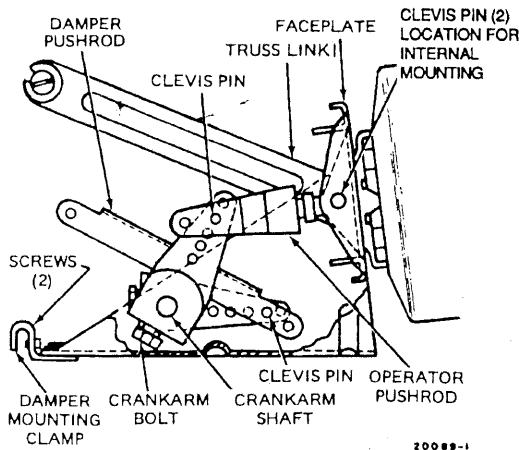

Fig. 30. Converting an Internally Mounted Normally Open Actuator to Externally Mounted.

CONVERTING INTERNALLY MOUNTED NORMALLY CLOSED ACTUATOR TO EXTERNAL MOUNTING

1. Obtain the following additional parts:
 - Push Rod Assembly: 14004106-001
 - Crankarm Assembly: 14004107-001
 - Mounting Screw Assembly: 14004237-001

2. Loosen two damper mounting clamp screws and remove clamp if necessary (Fig. 30).
3. Loosen faceplate nut, remove truss link, and retighten nut.
4. Remove clevis pins and actuator (Fig. 31).
5. Remove factory-installed pushrod.
6. Loosen locknut and adjust pushrod to dimensions shown on Figure 30. Tighten locknut.
7. Install crankarm on pushrod with a clevis pin.
8. Install actuator with standard external mounting instructions.

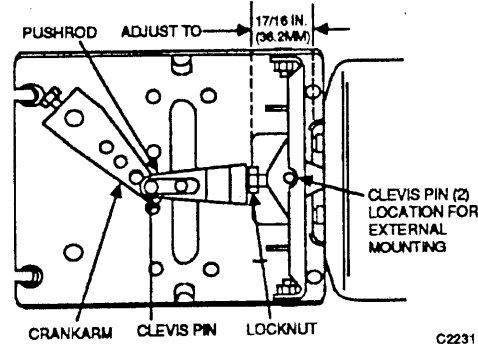

Fig. 31. Clevis Pin Locations.

PIPING

MP918A ACTUATOR PIPING

1. Connect 5/32-inch (4 mm) O.D. plastic tubing per job drawings to pilot port (P) of positive positioner.
2. Connect 1/4-inch (6 mm) O.D. plastic tubing from main line to main port (M).
3. See SLAVE ACTUATOR PIPING if slaving is desired.
4. Go to POSITIONER ADJUSTMENT section.

MP918B ACTUATOR PIPING

1. Connect 1/4-inch (6 mm) O.D. plastic tubing per job drawings to actuator inlet port.
2. MP918B installation is complete.

SLAVE ACTUATOR PIPING

Slaving damper actuators (Fig. 32) together provides increased capacity to operate large damper installations. Any actuators used in slave operation with an MP918A must have 8 to 13 psi (55 to 90 kPa) spring range. The MP918A branch line from positive positioner to actuator must be cut, a 1/4-inch (6 mm) tee inserted, and a line run to slave actuators.

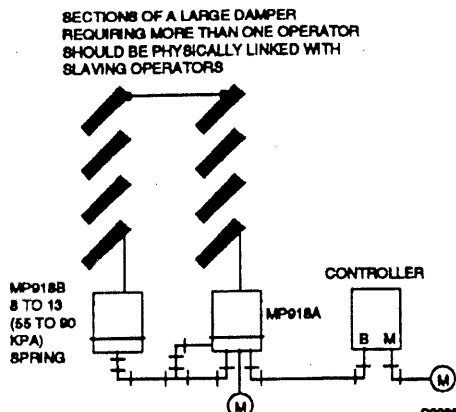
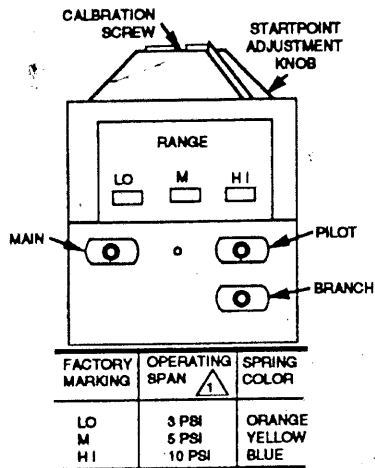

Fig. 32. MP918B Slave to MP918A for Large Damper Installations.

POSITIONER ADJUSTMENT (MP918A Only)

NOTE: Ensure that the positioner feedback spring is not binding on the positioner support.

The MP918A is shipped with one of the following feedback springs: 14004012-001, 3 psi (21 kPa); 14004013-001, 5 psi (35 kPa); or 14004014-001, 10 psi (69 kPa). The original feedback spring range is marked on the side of the positive positioner (Fig. 33). If the original feedback spring is satisfactory, set the start point adjustment only. If the feedback spring is changed, calibrate the positioner first and then set the start point adjustment. Adjustment of the MP918A is then complete.



1 IN CRITICAL SEQUENCING APPLICATIONS,
DERATE OPERATING SPAN BY 12-1/2 PERCENT

Fig. 33. Original Feedback Spring Marking.

Figure 34 shows the proper feedback spring hook location related to the three available spans of 3, 5, and 10 psi (21, 35, and 69 kPa). Use of the 3 psi (21 kPa) spring in the hole location shown will cause the start point calibration to shift approximately 1/2 psi (3.4 kPa). If this is unacceptable, recalibrate the unit.

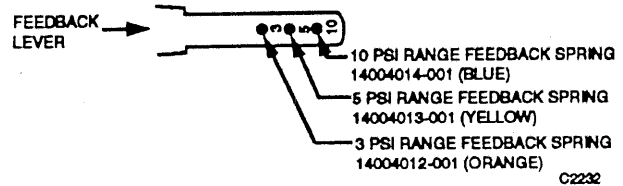

Fig. 34. Feedback Spring Hook Location.

START POINT ADJUSTMENT

Set the start point on positioner to the value specified in job drawings. Each click of the start point knob adjusts the start point 1/4 psi (1.7 kPa). To lock start point, tighten locking setscrew (Fig. 4) with a 5/16-inch Allen wrench.

CALIBRATION ADJUSTMENT

1. Check that the branch line of the positioner is piped to the actuator inlet port.
2. Supply main air to the positioner.
3. Connect the positioner pilot port to a variable air source such as a squeeze bulb or PRV and pressure gage.
4. Set start point knob to indicate a 3-psi (21 kPa) start point. Slowly raise pressure on the pilot port to 3 psi. (21 kPa) The shaft should not move.
5. If the shaft moves, turn the calibration screw in the middle of the start point knob clockwise until the shaft is retracted.
6. Turn the calibration screw in the middle of the start point knob counterclockwise just until the shaft starts to move.

Home and Building Control
Honeywell Inc.
Honeywell Plaza
P.O. Box 524
Minneapolis, MN 55408-0524

Home and Building Control
Honeywell Limited-Honeywell Limitée
740 Ellesmere Road
Scarborough, Ontario
M1P 2V9

Helping You Control Your World